

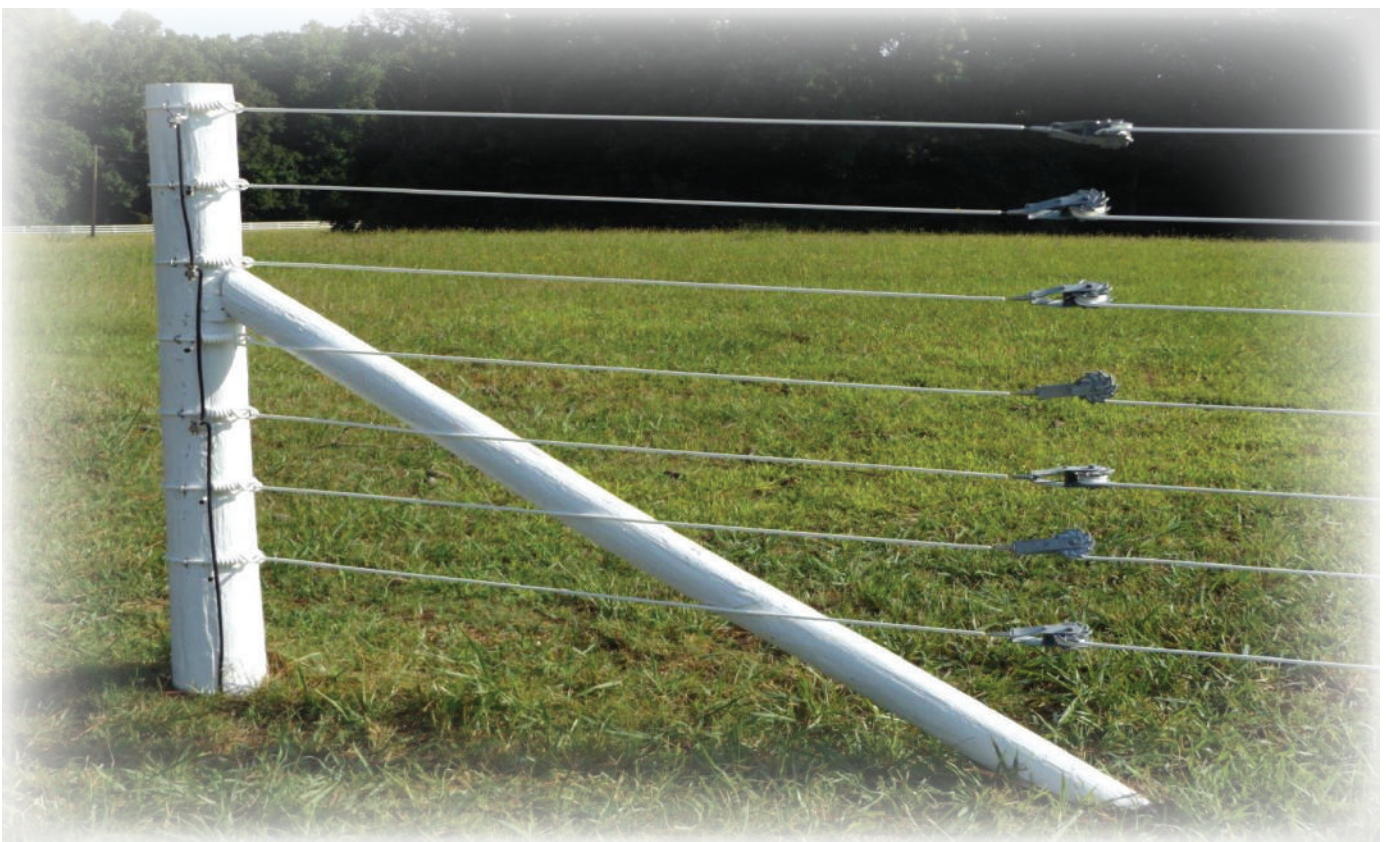

## Raceline / Shockline/Endloop Installation Manual



Scan this QR code  
to watch the  
Installation Video.



Trouble Shooting Hotline  
1-800-878-5644

# Flex Fence® Raceline/Shockline Fence Installation Guide

Before you layout your fence call 811. An 811 representative will take info about your project and notify appropriate utility companies to come out and mark buried lines so that you can dig safely around them. 811 is not responsible to indicate any lines you or the previous owner have run underground, for example: cable, septic etc. You are responsible for indicating where those lie.

Please follow directions for a long lasting installation that will not sag after tension is applied to the Flex Fence® Raceline and or Shockline rails.

**PROPER BRACING OF CORNER AND END POSTS IS THE KEY TO A QUALITY INSTALLATION.** Please note that all concrete footings need to extend past the frost line. All diagonally braced corner and end post footers should have a belled shaped bottom as shown in the diagrams and diagonal brace footers should be squared off as shown in the following drawings, or you can use the new all underground structure as outlined in this guide.

## POST REQUIREMENTS

Listed below are the post specification recommended for use with Flex Fence® Raceline and Shockline fencing. Use round wood posts for all applications (ends, corners, lines).

ALL WOOD POSTS MUST BE TREATED!

Post Type	*Post Diameter	Length	Hole Depth (12" diameter)
Line	4"-6"	7'-8'-9'	24"-36"
Corner	6" min	8'-9'	36" or below the frost line
Gate and/or end	6" min	8'-9'	36" or below the frost line
*Diagonal Braces with footers	4" min	7'	18" or below frost line

Note: The post diameters are to be measured on the small end.

## CONCRETE FOOTER REQUIREMENTS

Mix each 80lb bag of concrete according to the concrete manufacturer's methods found on the bag.

\*All concrete footer depths must be below the frost line for your area

\* If frost line is unknown talk with your local extension office

Concrete volumes for post footers can vary depending on hole size and soil conditions.

Northern states concrete requirements (approximate)

- (4) 80lb. bags for 6' x 9' corner/gate end posts.
- (4) 80lb. bags for each diagonal brace post

Southern States and areas south of mason dixon line. (frost line less than 18")

- (3) 80lb. bags for 6' x 9' corner/gate end posts.
- (2) 80lb. bags for each diagonal post



\*or equivalent

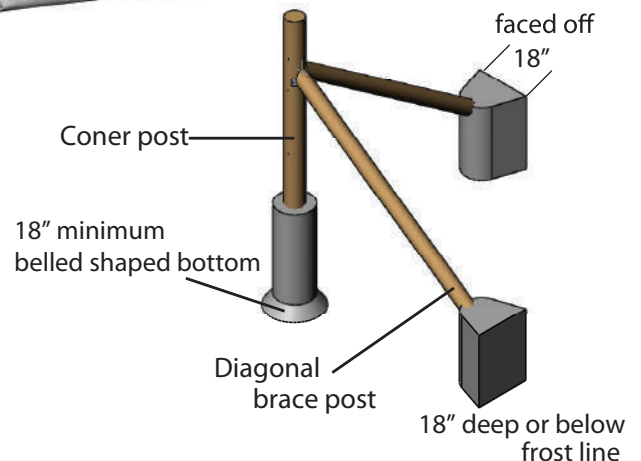

(Can be replaced with alternative gate or corner post without diagonal bracing see page 5)



# Tools Equipment and Hardware

1. Marking Pen
2. String line and Marking Paint
3. Tape Measure-25ft minimum
4. Chain saw
5. Post hole digger, tamping bar and spade shovel
6. Utility Knife and blades
7. Lineman pliers (heavy duty)
8. Hammers (claw and 2lb Sledge)
9. 12" auger (36"- 48" as required)
10. Paint brush or Roller for painting posts
11. Safety glasses
12. Spinning jenny #SJ
13. Stakes
14. High tensile wire cutters #WC
15. Pivot Square
16. Level

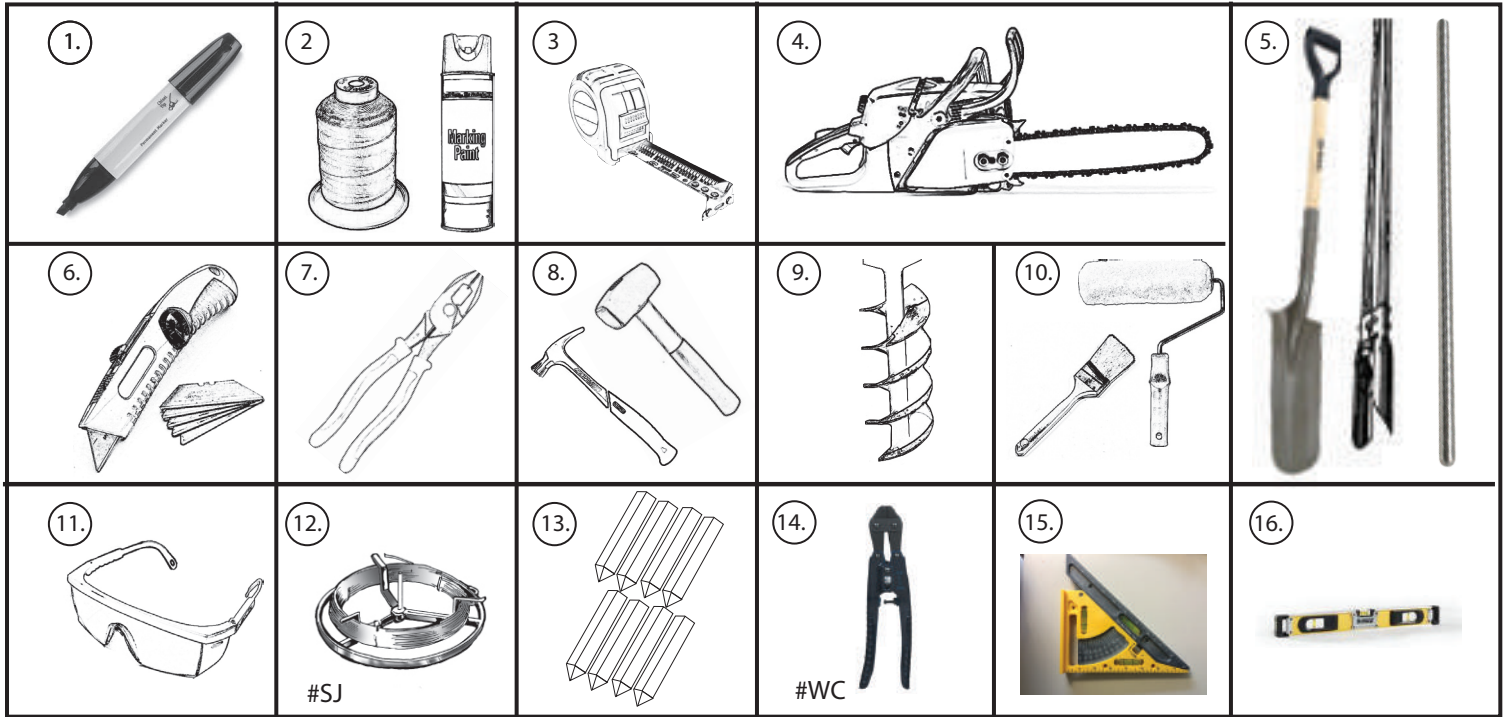

# Fencing Components and Supplies

- A. Corner/end posts #69P
- B. Diagonal brace posts #48P OR 58P
- C. Concrete
- D. Rolls of High Impact raceline #RC (W,B,BR)
- E. Rolls of high impact shockline # 1320SL (W,B,BR)
- F. Brace Plate #BRACEPLATE
- G. S bolt- #SBOLT
- H. PVC pipe and elbows 1/2" (for Buried electric line)
- I. Tensioner- #RTI
- J. Line Post High Impact Insulator- #ICC(W,B)
- K. End loop assembly- #ELA (W,B,BR)
- L. Homemade template

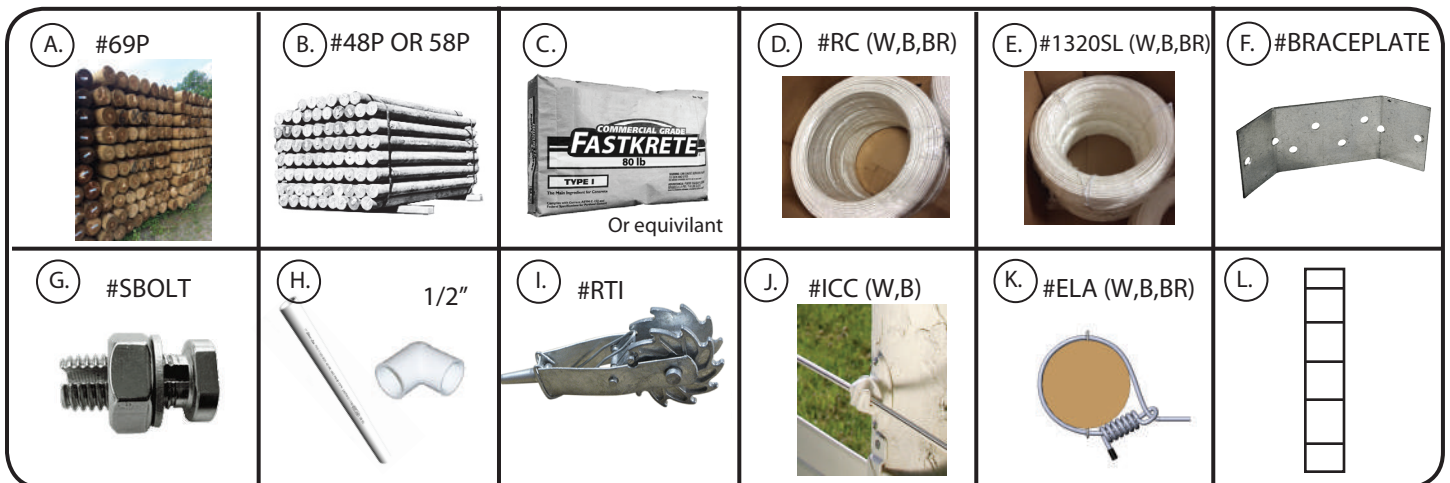

**Step 1** Call local utilities before digging (dial 811 they will mark your utility lines.)

**Step 2** Gather necessary tools- see page 2 for details.

**Step 3** Typical Post Installation Specifics.

See the diagram below and on the following pages.

### A. Line Post

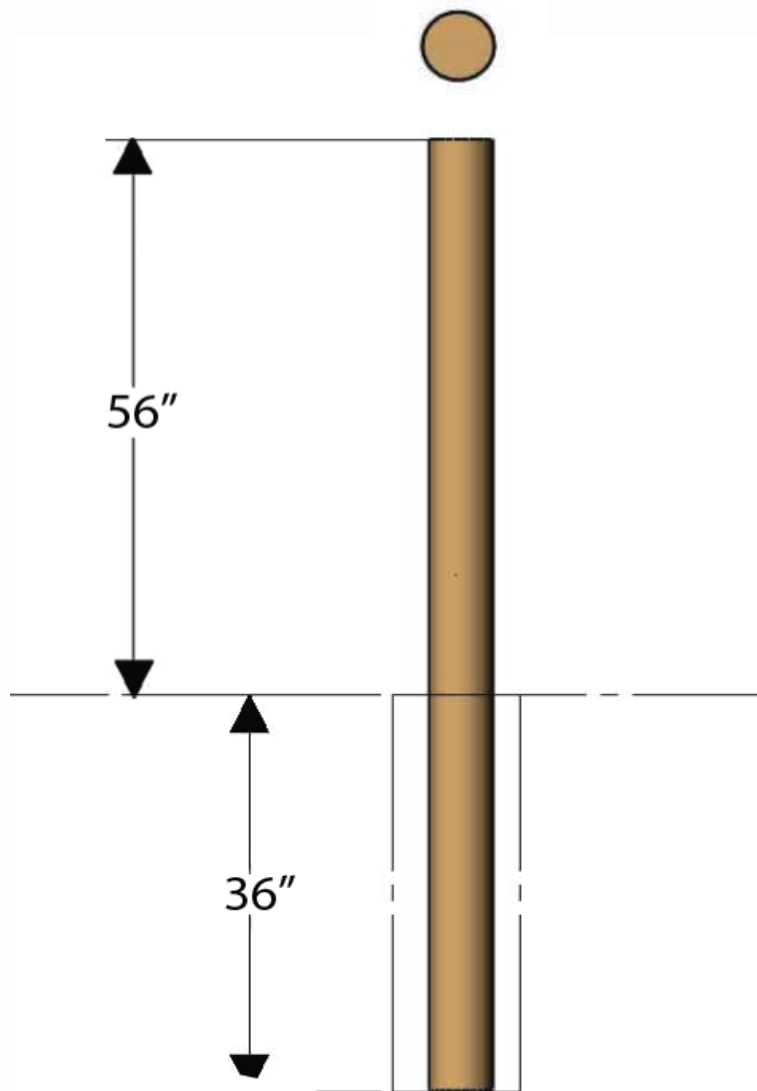

## B. End Post

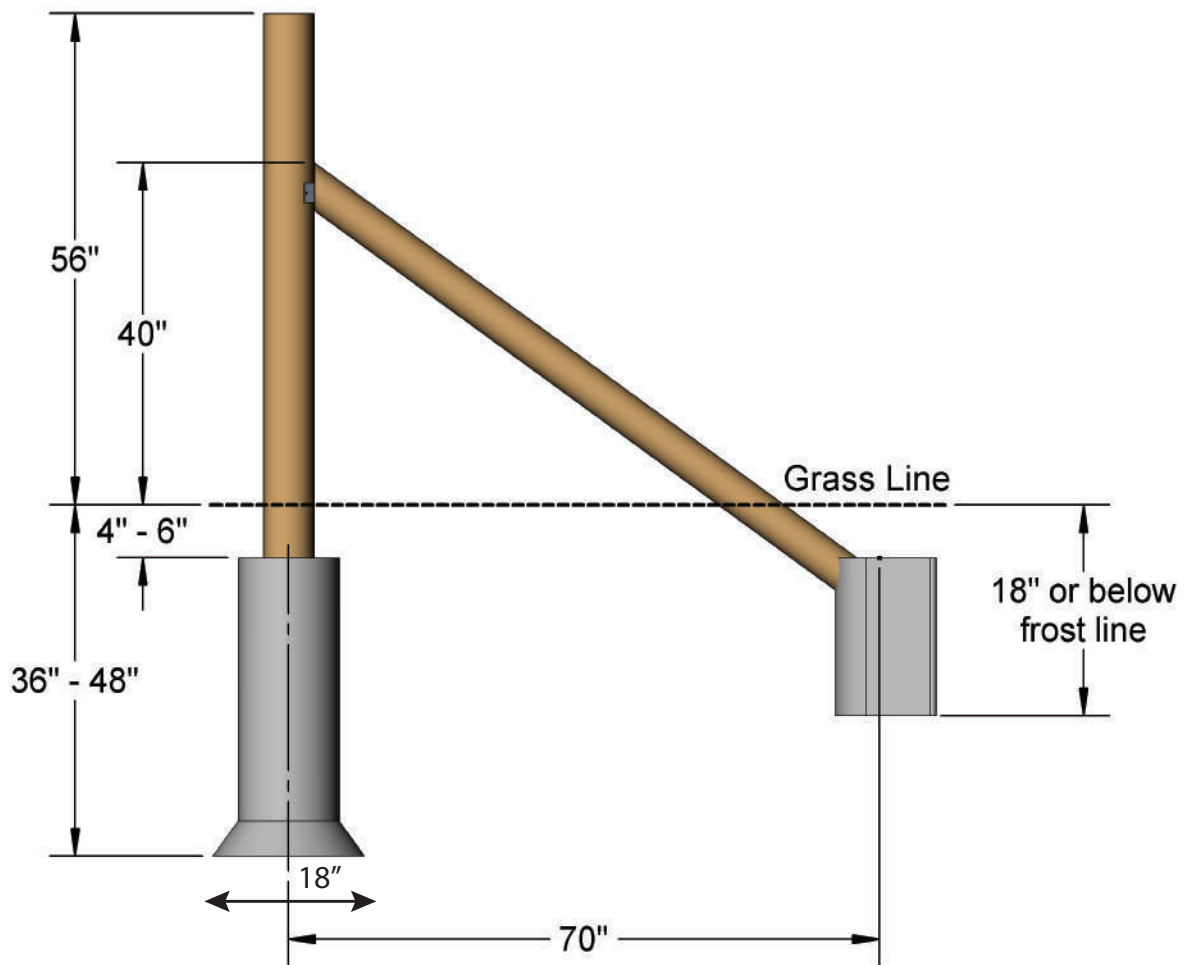

### C. Corner Post

Note: All diagonal posts are to be in the concrete approximately 1"-2"

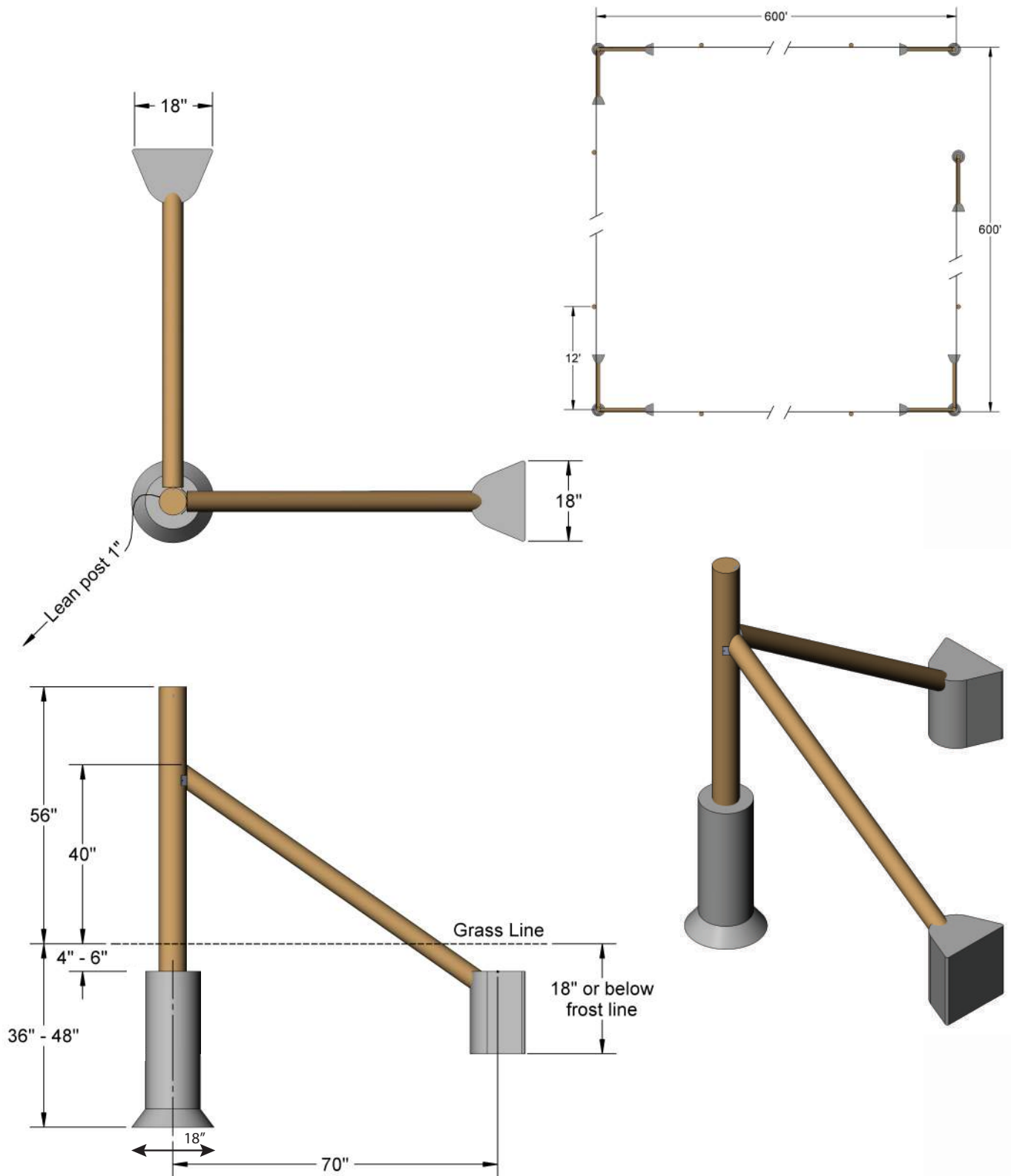

## D. Alternative Gate or Corner Post

Note:

A. Alternative structure for B & C without Diagonal Bracing

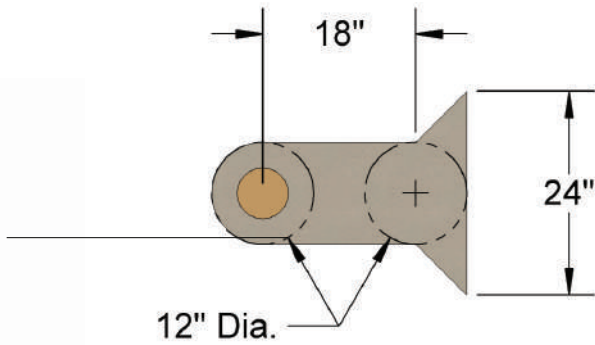

← Lean Post 1"

56"

Grass Line

18" or below  
frost line

Ø 12"

30"

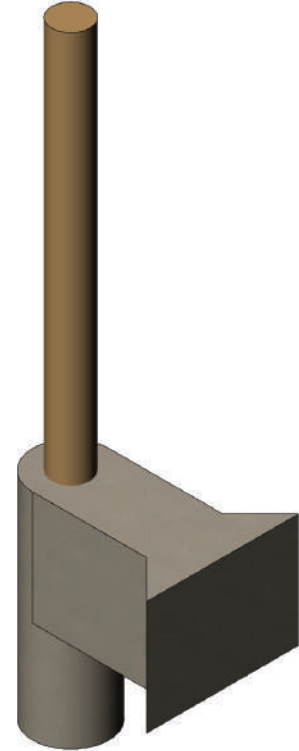

### Step 3 Cont.

#### A. Line post:

- Typical line post with tamped soil (ground level indicated by dashed line)
- The depth of the hole should be 24"-36" deep.
- Set your posts at 58" above ground level before flow is determined
- The post will be cut off after the flow of the fence has been determined (See diagram Step 3A on page 3)

#### B. End post:

- Typical end post with concrete illustrated (ground level indicated by dashed line)
- Note: end post should be set to lean approximately 1" away from tension to ensure level post after tension is applied. (See diagram Step 3B on page 4)

\*\* All footers must be below frost line

#### C. Corner post:

- Typical corner with concrete illustrated (ground level indicated by dashed lines)
- Note end post should be set to lean approximately 1" away from tension to ensure level post after tension is applied. (See diagram Step 3C on page 5)

\*\* All footers must be below frost line

#### D. Alternative gate or corner post without diagonal bracing:

- Drill two, 12" dia holes 18" apart
- One for the 6" gate/corner post, to be placed in the hole as shown in the diagram 2 on next page.
- Place the 6" dia. post in the hole away from the faced off area.
- Both will need to be below frost line. One will be faced off 24" wide and 18" deep. (See diagram Step 3D on page 6)

### Step 4 Layout fence line perimeter (example on next page 600' x 600' perimeter)

#### A. Locate all corner and gate posts.

B. Run string lines (dashed line) approximately 6' past corners and stake (solid black squares) into ground as shown in sketch on page 9.

C. To assure square corners use the 3'4'5' triangle method corner (as shown in sketch on page 9)

D. Use marking paint to mark each post location with an 'X' this should include all gate/end, corner, diagonal brace and line post locations. (Line post spacing recommended at 12' apart.)

E. When placing a gate in the corner set the corner post to the outside of string line as shown in corner

F. When running rails to the inside of an area, make sure the corner and end posts are inset so the rail can be run around the outside of these posts. This will allow the rail to run next to and past each line post. (as shown in sketch on page 9)



- A. It is your option to select a bracing structure for your corner and end posts.  
For example: With or without diagonally bracing
- B. The fence is representative as a solid line along the perimeter. See how the fence goes around the corner post and then back inside for the line post.

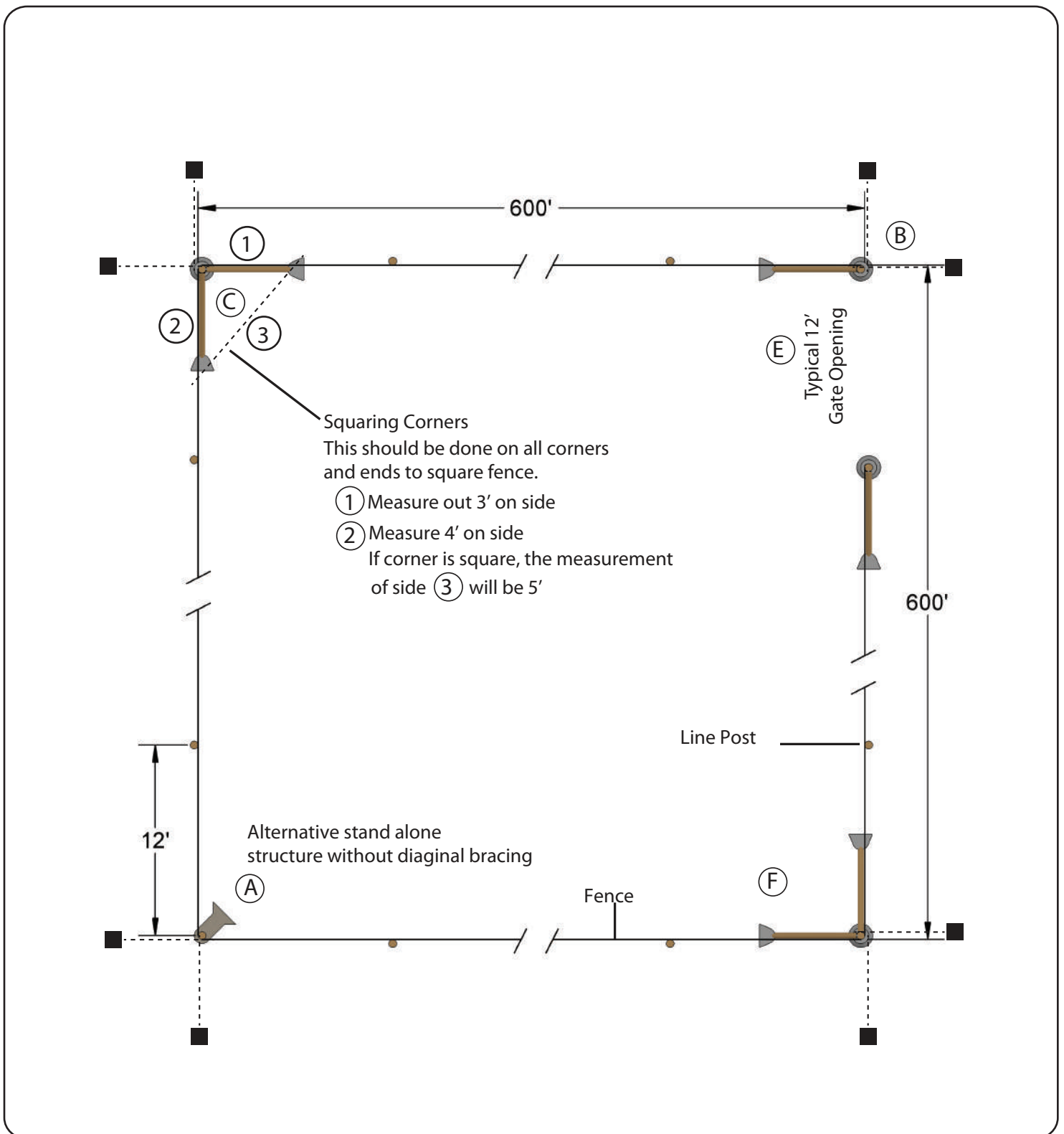

**Step 5** Dig all holes using a 12" auger.

**Step 6** The use of concrete

- A. The corner and end post need to be set in concrete as shown in diagrams on pages 3-6, this holds true whether you choose to use a diagonally braced structure or the alternative.

NOTE: Make sure all concrete is cured prior to tightening the rails.

**Step 7** Set Line Posts

- A. Place line posts into line post holes, which are 24"-36" deep along the string line.  
B. Level posts in both directions then add some dirt.  
C. Tamp soil around line posts. Do this by adding 3"-6" segments of soil (tamp soil between segments).  
D. Continue tamping process until hole is filled to ground level around line posts.

### Alternative gate or corner post without diagonal bracing

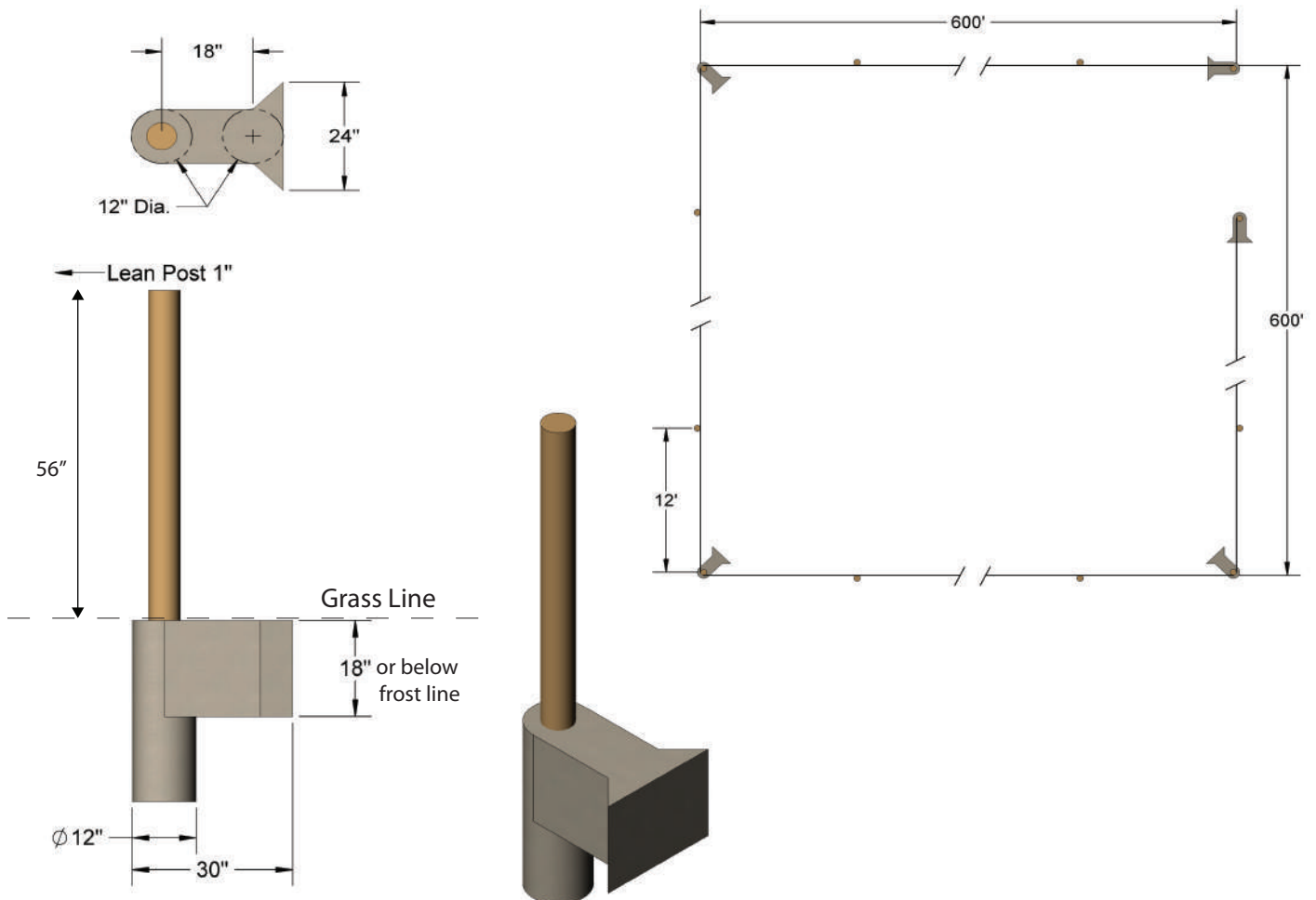

**Step 8** Establish post top line for proper flow of fencing.

- A. Mark on the side of the post a small line at 54" from the ground using a tape measure.  
Do this on all posts.
- B. Starting at the gate/end post using a thick and visible string wrapping it tightly around every post.
- C. Make sure it is tight between each post.
- D. Site over the string line and you will see abrupt changes in the flow. By raising and lowering the string line you can make the flow smooth from post to post.
- E. Keep the corner/gate/end posts string at the 54" mark, do not move the string line on them.
- F. You are looking for the average height of your fence over the entire length. Step back 30'-40' and make sure your satisfied with the flow of the fence.
- G. Make sure you are satisfied with your flow of the string line because it will influence the overall appearance of the fence itself. Take your time. A proper flow makes for a beautiful fence.
- H. Look at your string line from various directions.
- I. More than one opinion is helpful.

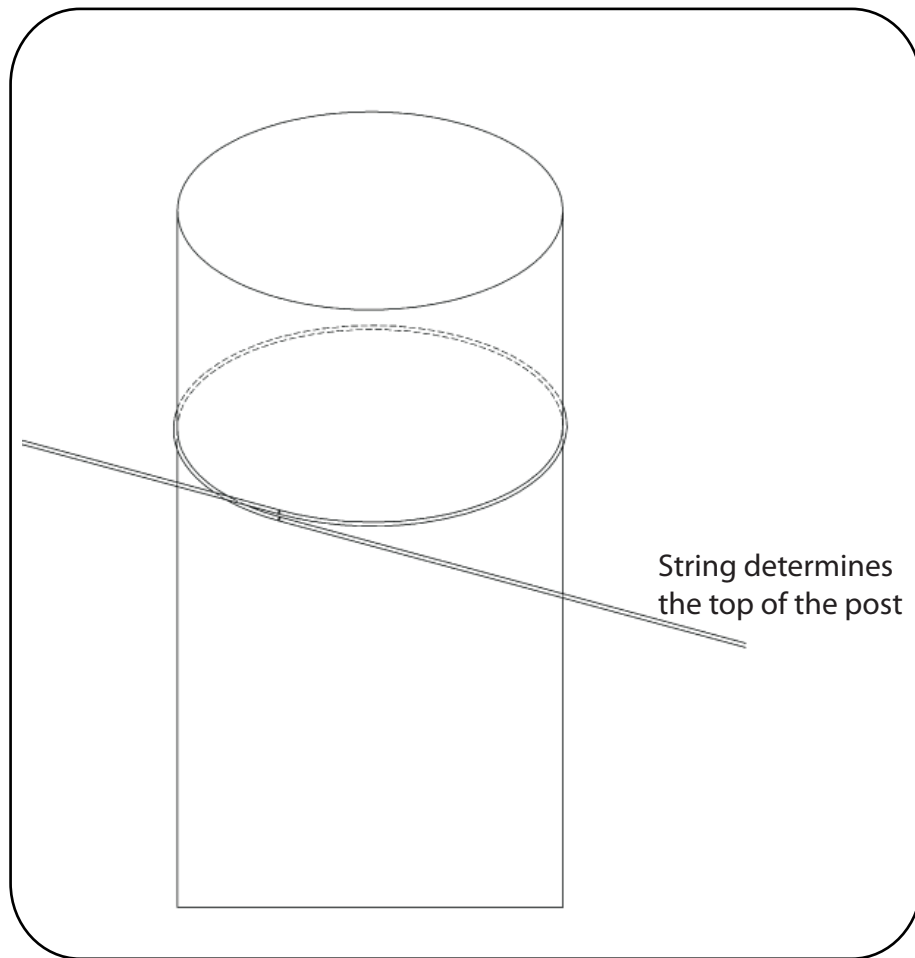

## End posts that are diagonally braced

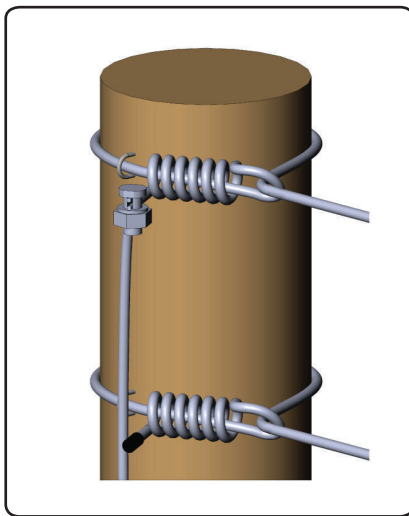

End Post Material List		
ITEM #	PART NAME	QTY.
1	gate/end post	1
2	diagonal brace post	1
3	diagonal brace plate	1
4	inline tensioner	7
5	insulated jumper wire	2
6	3.5" nail for braceplate	8
7	post footer (concrete)	1
8	brace post footer (concrete)	1
9	barbed fence staple	14
10	underground burial cable	1
11	PVC pipe	1
12	split bolt	3
13	end loop assembly	7

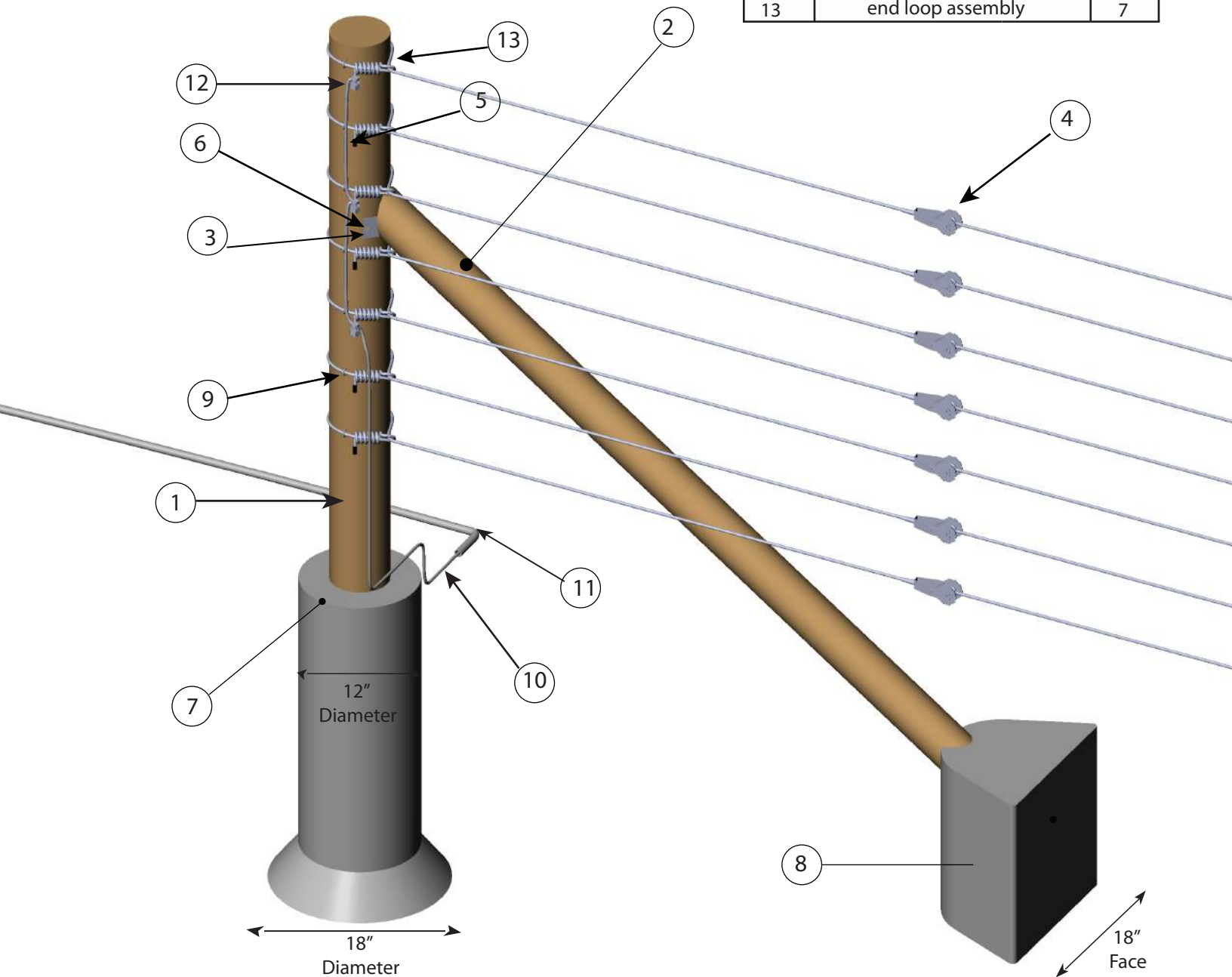

# Alternative gate or corner post structure without diagonal bracing

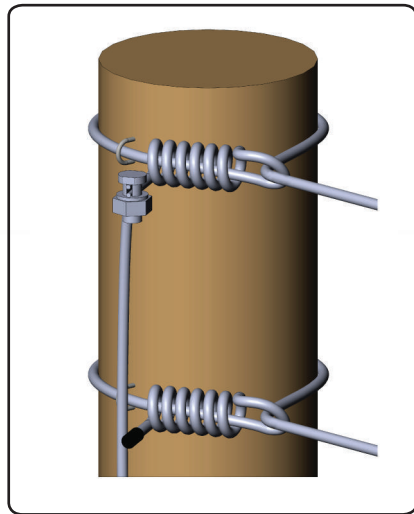

End Post Material List		
ITEM #	PART NAME	QTY.
1	gate/end post	1
2	inline tensioner	7
3	insulated jumper wires	2
4	post footer (concrete)	1
5	barbed fence staple	14
6	underground burial cable	1
7	PVC pipe	1
8	split bolt	3
9	end loop assembly	7

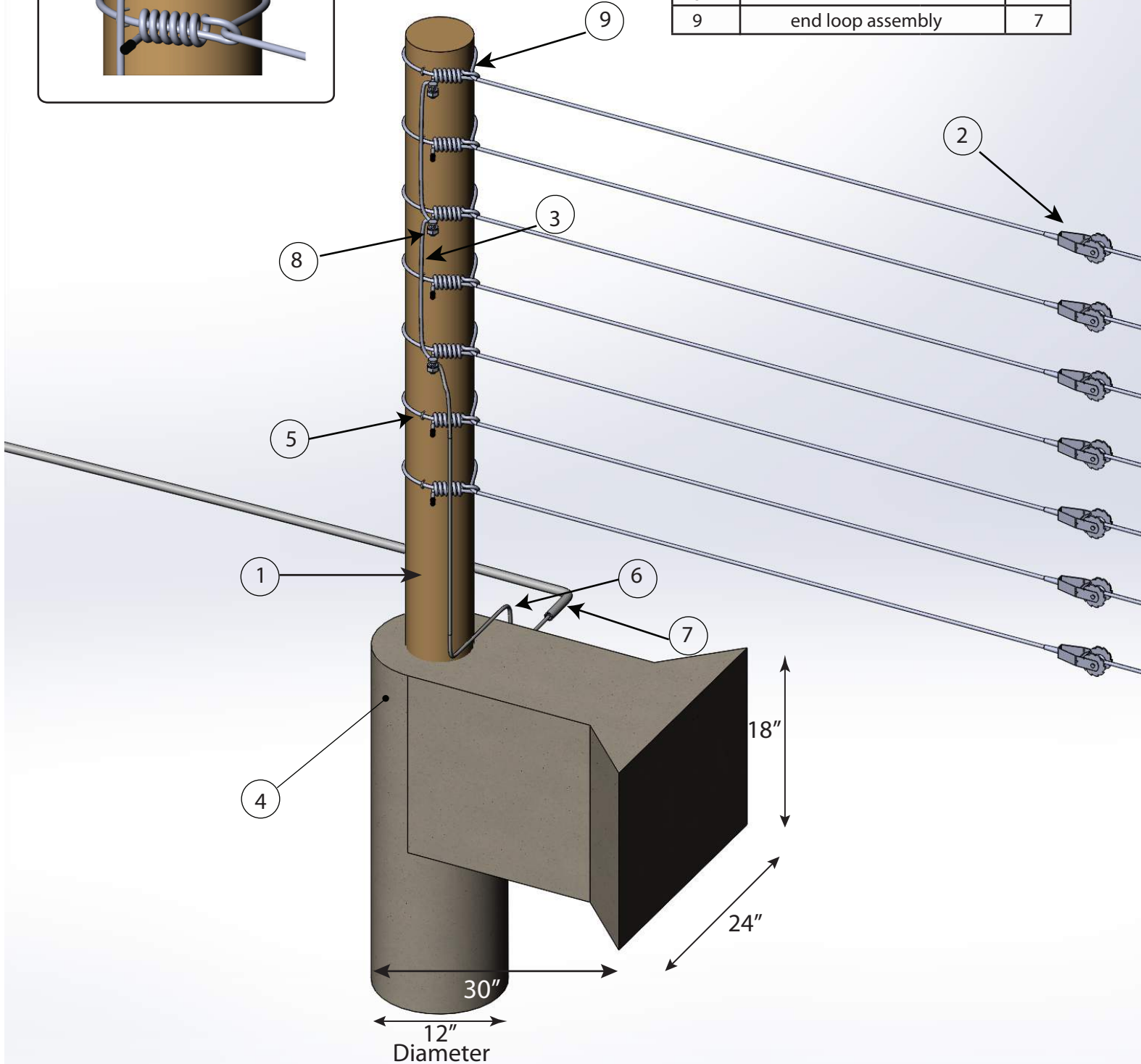

## Typical spacing for a 7 rail Flex Fence® Raceline/ Shockline products

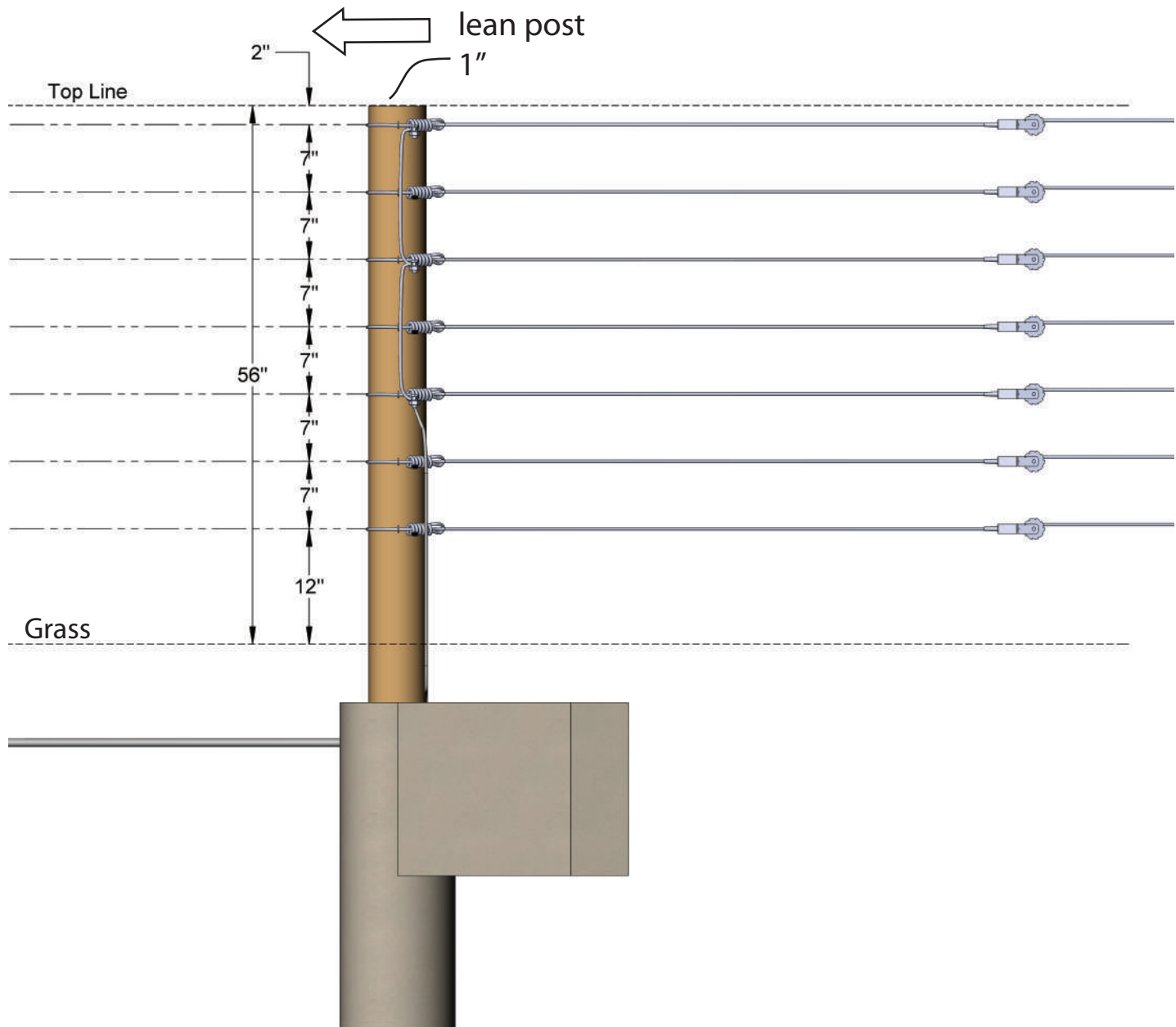

### Step 9 Marking Posts.

- Mark the new string line on the rail side.
- The string line is the top of your post and will be cut off with a chain saw. Make sure you use your homemade template and mark all rail locations accordingly.
- Remove your string
- Cut the post top off at the top mark (string line mark)
- This illustration is for 7 rails only. Your spacing will vary with different amounts of Flex Fence® Shockline/Raceline products.

## Step 10 Attach Flex Fence® Raceline/Shockline End Loops to end posts

- A. Hammer 2 staples half way in the end post at each mark. In our example it will be 14 locations. Two per rail. Do the same on the matching end post at the opposite end. **WARNING:** It is important that the staples are not completely hammered in and remain 1/8 of an inch away from the wire. Never completely tight!
- B. Select which side of the posts you will install your Flex Fence® Raceline and or Shockline rails.
- C. Using the "tail" of your end loop feed them into each set of staples. The first staple you feed will be the side you selected your rail to be on.
- D. Lace the tail end through the eye of the coil as shown.
- E. Hammer all staples into post up to 1/8" away, never tight.
- F. Do this at all 7 locations for this example.
- G. Do the same on the opposite end post-again at all locations.

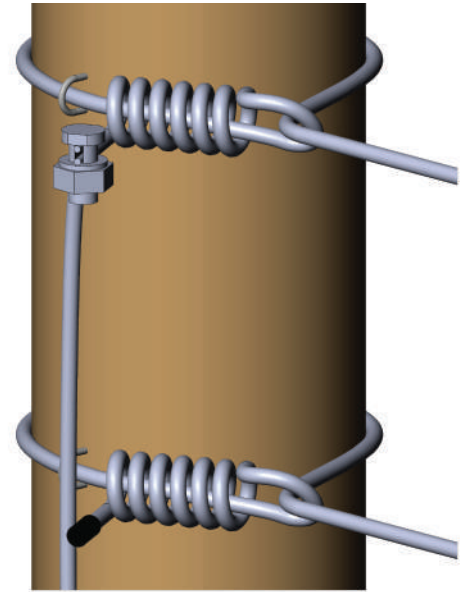
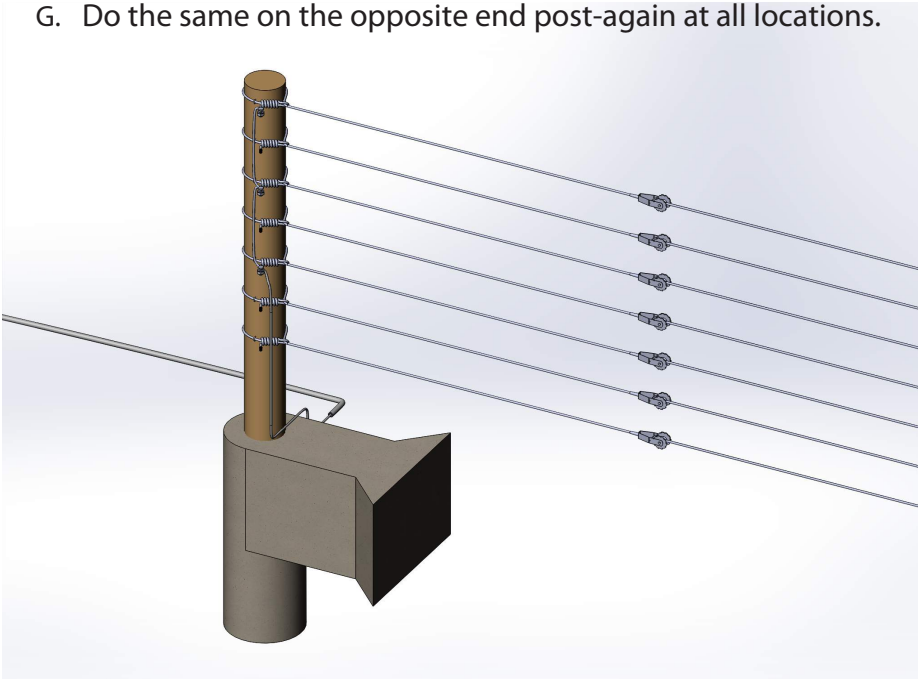

Staple Detail

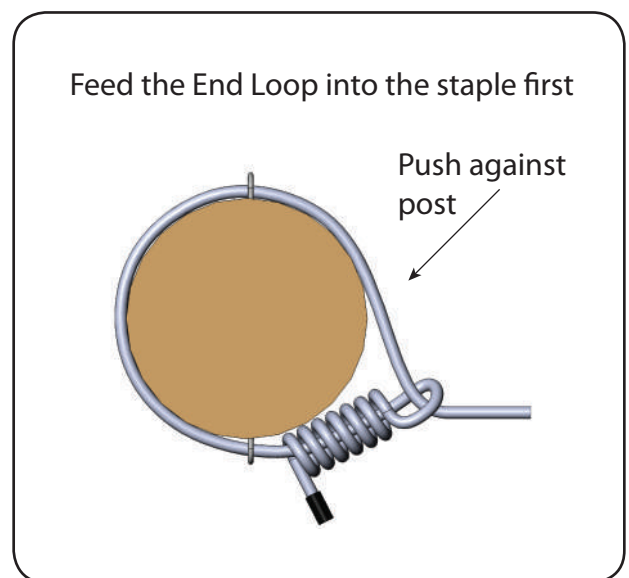
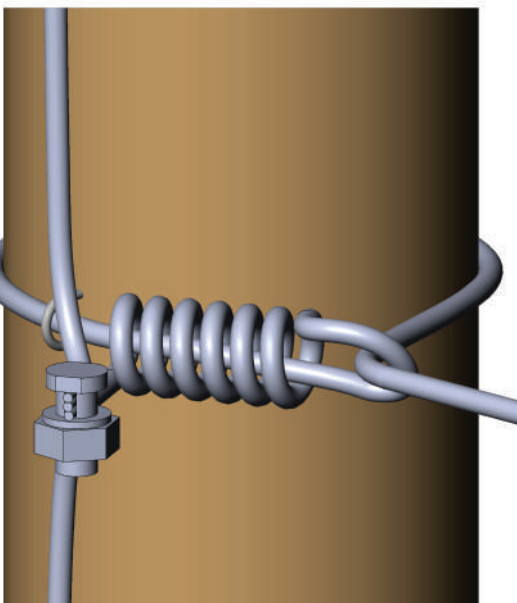

## Step 11 Paying out the Flex Fence Raceline and or Shockline rails

- A. NOTE: ALL OF OUR COATED PRODUCTS ARE DESIGNED TO RUN ON THE INSIDE OF PASTURES NEXT TO YOUR ANIMAL EXCEPT AROUND CORNERS.
- B. Pull out Raceline and or Shockline around your fence perimeter. THE USE OF A SPINNING JENNY IS REQUIRED FOR PAYING OUT YOUR FLEX FENCE®.
- C. Staple your Raceline to line and corner posts at your pre-marked points of each post.
- D. Do the same with Flex Fence® Shockline except use insulators instead of staples at your premarked points of each post.
- E. At the corner posts it's recommended to use 3 insulators at each location. It is important to put the Shockline in the 3 insulators and then attach them to the corner post.

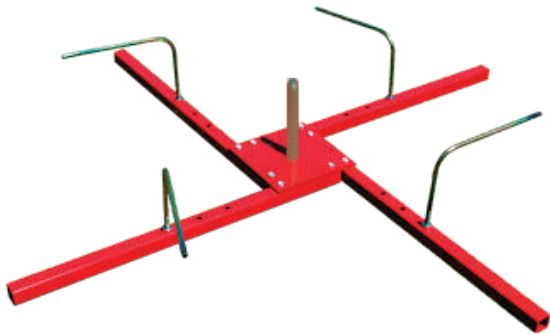

Spinning Jenny

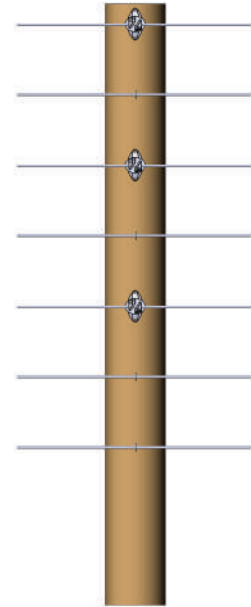

Typical Spacing for Raceline with Staples and Shockline with Insulators

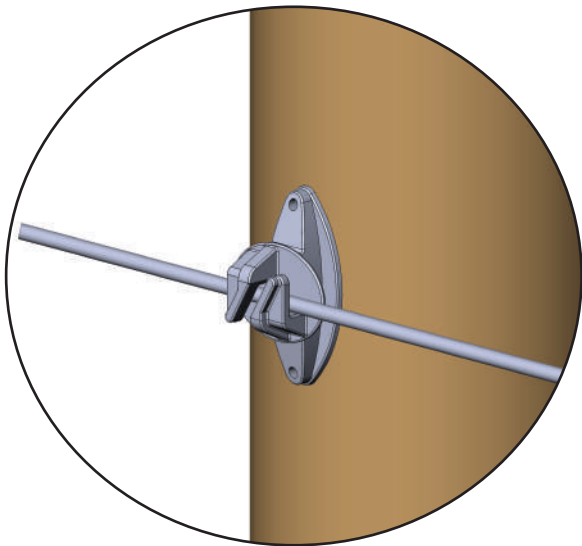

Detail for Flex Fence® Shockline Installation

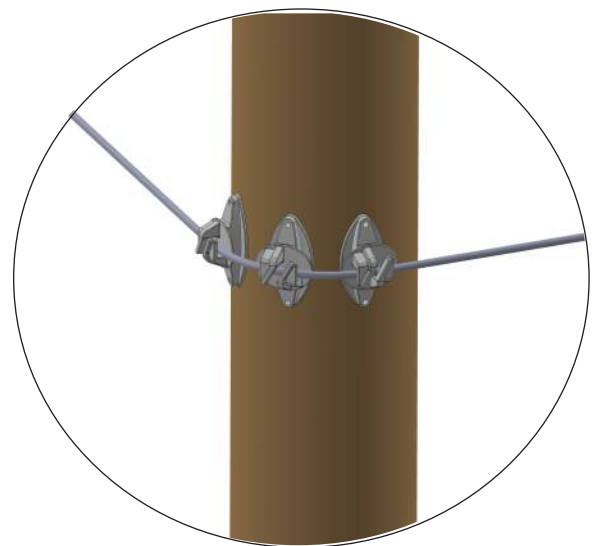

Detail for Flex Fence® Shockline Insulator around a corner



## Step 12 Tensioner Installations

- A. Remove 1 1/4" of polymer off the tail of each Flex Fence® End Loop as shown.
- B. Insert bare wire into the cone of your tensioner. Do this on all wires.
- C. Do this at all locations.

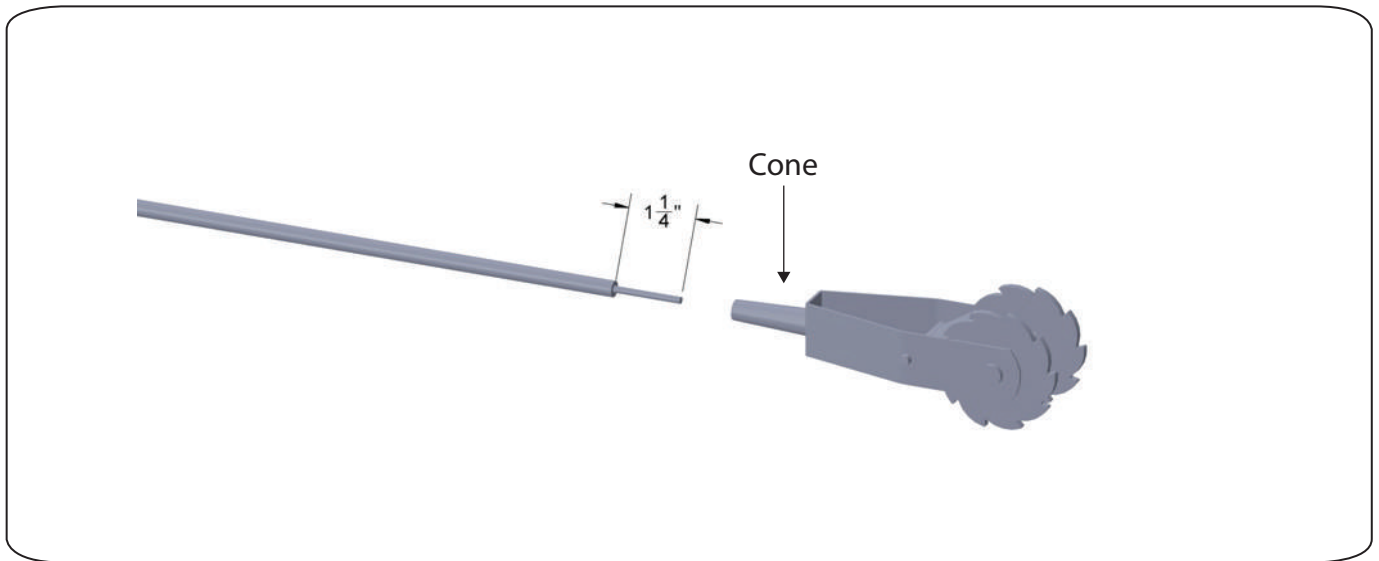

- Step 13 Concrete is to cure per manufacturers recommendation. Never put any pressure on end and or corner posts without letting the concrete cure.

## Step 14 Attaching End Loops to Flex Fence® Raceline/ Shockline rails

- A. Start at one end of your fence, and remove 5" of polymer off the wire. Do this on all rails using a utility knife. NOTE: Make sure you always push the knife away from your body.
- B. Insert bare wire into hole in the matching tensioner spool and with the aid of linemans pliers bend the end of the wire over about a half of inch in length making it 90°.
- C. With the aid of a tensioner handle ratchet up the 5" of bare wire including a couple wraps with polymer onto the tensioner spool. Do this on all tensioners at this end.

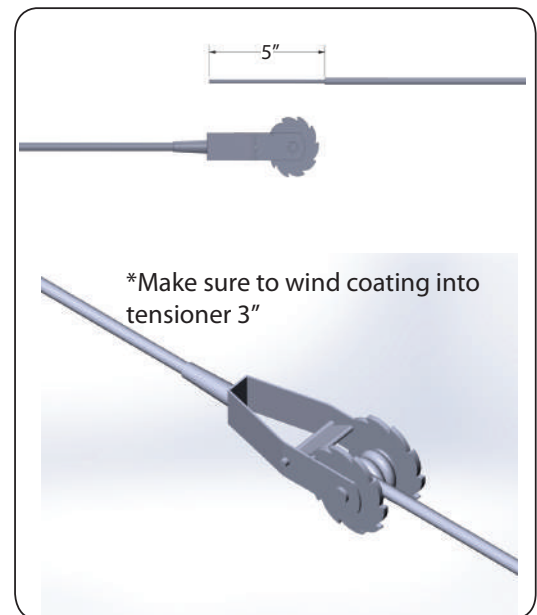

## Step 15 Attaching End Loops and tightening rail

- A. Go to the other end of your fence run.
- B. Pull all slack out of your rails back toward these tensioners.
- C. Pull rail past tensioner about 5" and cut off access rail at this point.
- D. Strip back about 5" of polymer using a utility knife.
- E. Insert bare wire into hole in tensioner spool and with lineman pliers bend the end of the wire over about half of an inch in length making it 90°
- F. With tensioner handle ratchet up all rails making them tight.

**NOTE:** YOU NEED TO MAKE SURE THE POLYMER IS SPOOLED INTO THE TENSIONER DURING THIS OPERATION.

## Step 16 Hooking up your charger to your Flex Fence® Shockline

- A. Cut a proper length of burial cable to use as jumpers between the End Loops. This wire should be about 3" longer than the distance between the Shockline rails.
- B. Strip off about 1" of plastic from both ends of the pre-measured jumpers then bend this bare wire 90°.
- C. Remove 1" of polymer including cap off of the End Loops that are attached to your Shockline rail. Do this to all Shockline rails.
- D. Attach necessary split bolts at each jumper locations tying it into the underground burial cable that runs into your charger.
- E. Staple underground burial cable to the post as required.

**NOTE:** NEVER DRIVE IN THE STAPLE TOO TIGHT. KEEP IT LOOSE.

- F. Installation is complete when you turn on your electric charger. Check for current in Shockline then let your animals in.

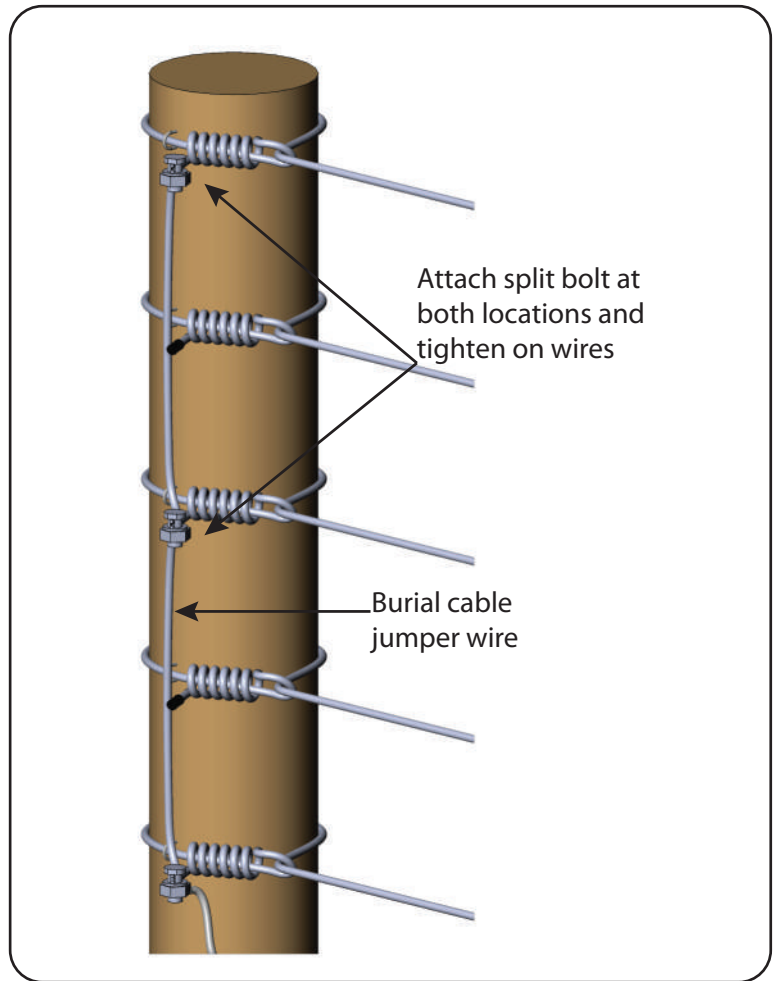
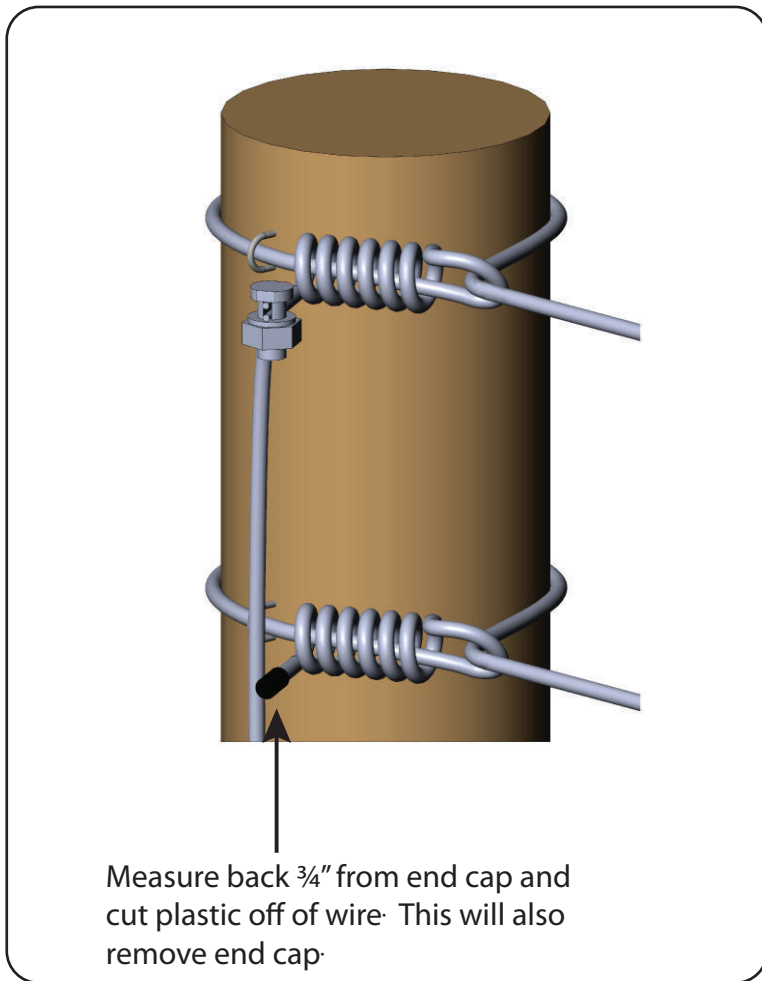

The information contained in this document is the sole property of RAMM Horse Fencing and Horse stalls. Any reproduction in part or as a whole without the written permission of RAMM Horse Fencing and Horse Stalls is prohibited. 2015

No fence product is totally safe. There remains potential for injury to animals; therefore the manufacturer shall in no event be responsible for any injury to persons, animals or personal property. Also, electrifying your fence runs will help to keep animals off of it.

For additional help please call 1-877-419-7266